

Centre Scientifique et
Technique du Bâtiment

84 avenue Jean Jaurès
CHAMPS-SUR-MARNE
F-77447 Marne-la-Vallée Cedex 2

Tél. : (33) 01 64 68 82 82

Fax : (33) 01 60 05 70 37

**European Technical
Assessment**

**ETA-13/0435
of 01/06/2018**

English translation prepared by CSTB - Original version in French language

General Part

Nom commercial
Trade name

SPIT MULTI-MAX

Famille de produit
Product family

Cheville à scellement de type "à injection" avec tige d'ancrage diamètres M8, M10, M12, M16, M20 et M24 pour fixation dans le béton non fissuré.

Bonded injection type anchor with anchor rod sizes M8, M10, M12, M16, M20 and M24 for use in non-cracked concrete.

Titulaire
Manufacturer

**SPIT SAS
Route de Lyon
26500 Bourg-Les-Valence
FRANCE**

Usine de fabrication
Manufacturing plant

**Société SPIT
Route de Lyon
FR-26501 BOURG-LES-VALENCE**

Cette évaluation contient:
This Assessment contains

14 pages incluant 11 annexes qui font partie intégrante de cette évaluation
14 pages including 11 annexes which form an integral part of this assessment

Base de l'ETE
Basis of ETA

**EAD 330499-00-601, Edition juillet 2017
*EAD 330499-00-601, Edition July 2017***

Cette évaluation remplace:
This Assessment replaces

**ATE - 13/0435 délivrée le 31/05/2013
*ETA- 13/0435 issued on 31/05/2013***

Translations of this European Technical Assessment in other languages shall fully correspond to the original issued document and should be identified as such. Communication of this European Technical Assessment, including transmission by electronic means, shall be in full. However, partial reproduction may be made, with the written consent of the issuing Technical Assessment Body. Any partial reproduction has to be identified as such.

1 Technical description of the product

The SPIT MULTI-MAX is a bonded anchor (injection type) with anchor rod made of galvanized steel or stainless steel or stainless steel high corrosion resistance (HCR), which is placed into a drilled hole previously injected with a two components injection mortar using an applicator gun equipped with a special mixing nozzle. The anchor rod is inserted into the resin with a slow and slight twisting motion. The mortar cartridges are available in different sizes 280 ml to 410 ml

The anchor rod is intended to be used with embedment depth from 8 diameters to 12 diameters

The illustration and the description of the product are given in Annex A1.

2 Specification of the intended use

The performances given in Section 3 are only valid if the anchor is used in compliance with the specifications and conditions given in Annexes B.

The provisions made in this European Technical Assessment are based on an assumed working life of the anchor of 50 years. The indications given on the working life cannot be interpreted as a guarantee given by the producer, but are to be regarded only as a means for choosing the right products in relation to the expected economically reasonable working life of the works.

3 Performance of the product

3.1 Mechanical resistance and stability (BWR 1)

Essential characteristic	Performance
Characteristic tension resistance and shear resistance for threaded rods acc. TR029	See Annex C1, C2
Characteristic tension resistance and shear resistance for threaded rods acc. CEN/TS 1992-4-5	See Annex C3, C4
Displacements	See Annex C1, C2

3.2 Safety in case of fire (BWR 2)

Essential characteristic	Performance
Reaction to fire	Anchorage satisfy requirements for Class A1
Resistance to fire	No performance determined (NPD)

3.3 Hygiene, health and the environment (BWR 3)

Regarding dangerous substances contained in this European Technical Assessment, there may be requirements applicable to the products falling within its scope (e.g. transposed European legislation and national laws, regulations and administrative provisions). In order to meet the provisions of the Construction Products Regulation, these requirements need also to be complied with, when and where they apply.

3.4 Safety in use (BWR 4)

For Basic Requirement Safety in Use the same criteria are valid as for Basic Requirement Mechanical Resistance and Stability.

3.5 Protection against noise (BWR 5)

Not relevant.

3.6 Energy economy and heat retention (BWR 6)

Not relevant.

3.7 Sustainable use of natural resources (BWR 7)

For the sustainable use of natural resources no performance was determined for this product.

3.8 General aspects relating to fitness for use

Durability and Serviceability are only ensured if the specifications of intended use according to Annex B1 are kept.

4 Assessment and Verification of Constancy of Performance (AVCP)

According to the Decision 96/582/EC of the European Commission¹, as amended, the system of assessment and verification of constancy of performance (see Annex V to Regulation (EU) No 305/2011) given in the following table apply.

Product	Intended use	Level or class	System
Metal anchors for use in concrete	For fixing and/or supporting to concrete, structural elements (which contributes to the stability of the works) or heavy units	—	1

5 Technical details necessary for the implementation of the AVCP system

Technical details necessary for the implementation of the Assessment and verification of constancy of performance (AVCP) system are laid down in the control plan deposited at Centre Scientifique et Technique du Bâtiment.

The manufacturer shall, on the basis of a contract, involve a notified body approved in the field of anchors for issuing the certificate of conformity CE based on the control plan.

Issued in Marne La Vallée on **01/06/2018** by
Charles Baloche
Directeur technique

The original French version is signed

¹ Official Journal of the European Communities L 254 of 08.10.1996

Injection mortar MULTI-MAX

Cartridge 380 ml and 410 ml

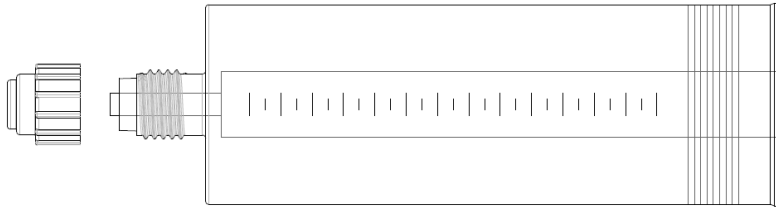

Cartridge 280 ml and 300 ml

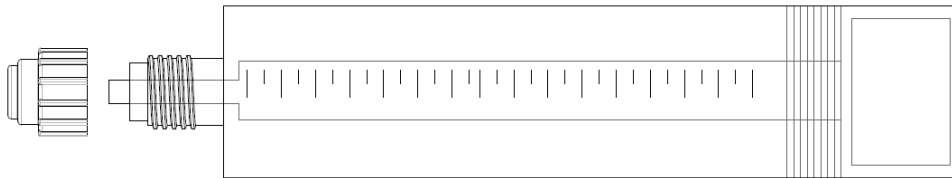

Mixing nozzles



Commercial standard threaded rods with identifying mark of the embedment depth

Intended use:

Use category 1 (according to EAD 330499-00-0601):

Overhead installation is permitted

Temperature ranges:

-40°C to +40°C (max. short term temperature +40°C and max. long term temperature +24°C)

SPIT MULTI-MAX

System Description

Annex A1

Table A1: Materials

Designation	Material
Injection mortar	Methacrylate resin, hardener and inorganic agents
Elements made of zinc coated steel	
Threaded rod M8 – M24 (standard commercial rods)	Strength class 5.8,6.8, 8.8, 10.9 EN ISO 898-1, Zinc coating $\geq 5\mu\text{m}$ NF E25-009,
Washer	Steel DIN 513 Zinc coating $\geq 5\mu\text{m}$ NF E25-009,
Nut	Steel, EN 20898-2 Grade 6 or 8 Zinc coating $\geq 5\mu\text{m}$ NF E25-009,
Elements made of stainless steel A4	
Threaded rod M8 – M24	Stainless steel A4-70: 1.4401; 1.4404; 1.4578; 1.4571; 1.4439; 1.4362 acc. EN 10088
Washer	Stainless steel A4-70: 1.4401; 1.4404; 1.4578; 1.4571; 1.4439; 1.4362 EN 10088
Nut	Strength class 80 EN ISO 3506-2 Stainless steel 1.4401; 1.4404; 1.4578; 1.4571; 1.4439; 1.4362 acc. EN 10088
Elements made of high corrosion resistant stainless steel	
Threaded rod M8 – M24	Stainless steel HCR $R_m \geq 650$ MPa Acc. EN 10088, 1.4529 / 1.4565
Washer	Stainless steel HCR Acc. EN 10088, 1.4529 / 1.4565
Nut	Stainless steel HCR $R_m \geq 650$ MPa Acc. EN 10088, 1.4529 / 1.4565

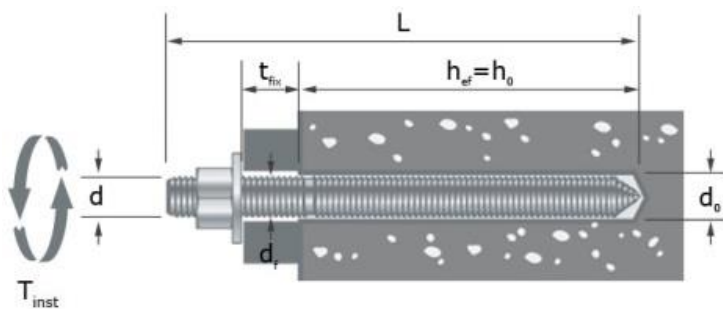



SPIT MULTI-MAX

Annex A2

Materials

Specifications of intended use

Table B1: Overview use categories and performance categories

Use conditions		Mortar capsule with ...	
		Threaded rods	
			
hammer drilling or compressed air drilling mode. 		✓	
Static and quasi static loading, in non-cracked concrete		M8 to M24 Tables C1, C2, C3, C4.	
Use category: dry or wet concrete (flooded holes are excluded)		✓	
Installation temperature (minimum)		mortar 0°C, concrete 0°C	
In-service temperature	Temperature range I:	-40°C to +40°C	(max long term temperature +24°C and max short term temperature +40°C)

Base materials:

- Reinforced or unreinforced normal weight concrete according to EN 206.
- Strength classes C20/25 to C50/60 according to EN 206.

Use conditions (Environmental conditions):

- Structures subject to dry internal conditions (zinc coated steel, stainless steel or high corrosion resistant steel).
- Structures subject to permanently damp internal condition :
 - if no particular aggressive conditions exist (stainless steel or high corrosion resistant steel).
 - with particular aggressive conditions (high corrosion resistant steel).
- Structures subject to external atmospheric exposure including industrial and marine environment :
 - if no particular aggressive conditions exist (stainless steel or high corrosion resistant steel).
 - with particular aggressive conditions (high corrosion resistant steel).

Note: Particular aggressive conditions are e.g. permanent, alternating immersion in seawater or the splash zone of seawater, chloride atmosphere of indoor swimming pools or atmosphere with extreme chemical pollution (e.g. in desulphurization plants or road tunnels where de-icing materials are used).

- Overhead installations are permitted

Design:

- Anchorages are designed under the responsibility of an engineer experienced in anchorages and concrete work.
- Verifiable calculation notes and drawings are prepared taking account of the forces to be transmitted. The position of the anchor is indicated on the design drawings (e. g. position of the anchor relative to reinforcement or to supports, etc.).
- Anchorages under static or quasi-static actions are designed in accordance with (please choose the relevant design method): EOTA Technical Report TR 029, Edition September 2010; CEN/TS 1992-4-5

SPIT MULTI-MAX

Annex B1

Intended use – specification

Table B2: Installation parameters

Dimension de la cheville			M8	M10	M12	M16	M20	M24
Nominal drill hole	d_0	[mm]	10	12	14	18	25	28
Depth of drill hole	$h_{0,min}$	[mm]	64	80	96	128	160	192
	$h_{0,max}$		96	120	144	192	240	288
Ø of clearance hole in the fixture ¹⁾	d_f	[mm]	9	12	14	18	22	26
Steel brush Ø	D	[mm]	11	13	15	20	26	30
Torque moment	T_{inst}	[Nm]	10	20	30	60	120	200

¹⁾ for larger clearance hole in the fixture see TR 029 section 1.1 and/or CEN/TS 1992-4-1:2009, section 1.2.3

Steel brush and installation procedure



Table B3: Minimum member thickness, edge distance and spacing

Dimension de la cheville			M8	M10	M12	M16	M20	M24
Min. member thickness	$h_{min,min}$	[mm]	100	110	126	164	210	248
	$h_{min,max}$		126	150	174	228	290	344
Min. edge distance	c_{min}	[mm]	40	50	60	80	100	120
Min. spacing	s_{min}	[mm]	40	50	60	80	100	120

Table B4: Minimum curing time

Temperature in the concrete member	Minimum curing time	Minimum curing time in wet concrete
≥ + 0 °C	18 min	180 min
≥ + 5 °C	12 min	90 min
≥ + 10 °C	6 min	60 min
≥ + 20 °C	4 min	45 min
≥ + 30 °C	2 min	35 min

SPIT MULTI-MAX

Installation instruction

Annex B2

Table B5 : Cleaning method

	Standard cleaning	Premium cleaning
Nominal diameter	All diameters	All diameters
Cleaning method	<p>4 blows+ 4 brushing operation + 4 blows</p> <p>Blowing operation: using a hand pomp, blow 4 times.</p> <p>Brushing operation: using the relevant brush, starting from the top of the hole, move downward to the bottom of the hole then move upward to the top of the hole.</p>	<p>2 blows+ 2 brushing operation + 2 blows</p> <p>Blowing operation: using oil free compressed air (mini 6 bars), starting from the bottom of the hole, move upward until no dust is evacuated.</p> <p>Brushing operation: using the relevant brush fitted on a SPIT drilling machine, starting from the top of the hole, move downward to the bottom of the hole (duration 5s) then move upward to the top of the hole (duration 5s)</p>

SPIT MULTI-MAX

Annex B3

Installation instruction

Instruction For Use: Standard cleaning

Manual cleaning is permitted for hammer drilled holes up to hole diameters $d_0 \leq 16\text{mm}$.

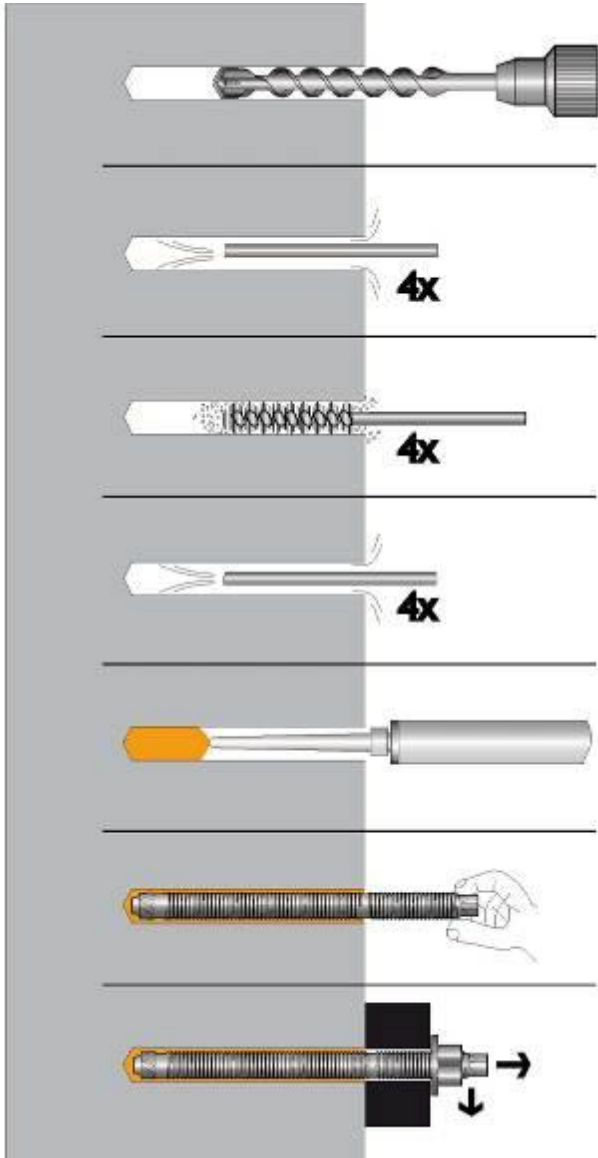

Drill hole of diameter (d_0) and depth (h_0) with a hammer drill set in rotation-hammer mode using an appropriately carbide drill bit.

4 strokes with SPIT blow-out pump from the back of the hole until return air stream is free of noticeable dust.

4 times with the specified brush size (brush diameter \geq borehole diameter d_0) by inserting the SPIT steel wire brush to the back of the hole with a twisting motion and removing.

4 strokes with SPIT blow-out pump from the back of the hole until return air stream is free of noticeable dust.

Screw the mixing nozzle onto the cartridge and dispense the first part to waste until an even colour is achieved for each new cartridge or mixing nozzle. Use tube extensions for holes deeper than 250 mm. Starting from the bottom of the hole fill uniformly. In order to avoid air pocket, withdraw slowly the mixing nozzle while injecting the resin. Fill the hole until 1/2 full.

Insert the rod or rebar, slowly and with a slight twisting motion in respect of the gel time indicated in table 4. Remove excess resin from around the mouth of the hole before it sets. Control the embedment depth

Do not disturb anchor between specified cure time (acc. to table 4)

Attach the fixture and tight the nut at the specified torque

SPIT MULTI-MAX

Installation instruction

Annex B3

Instruction For Use: Premium cleaning

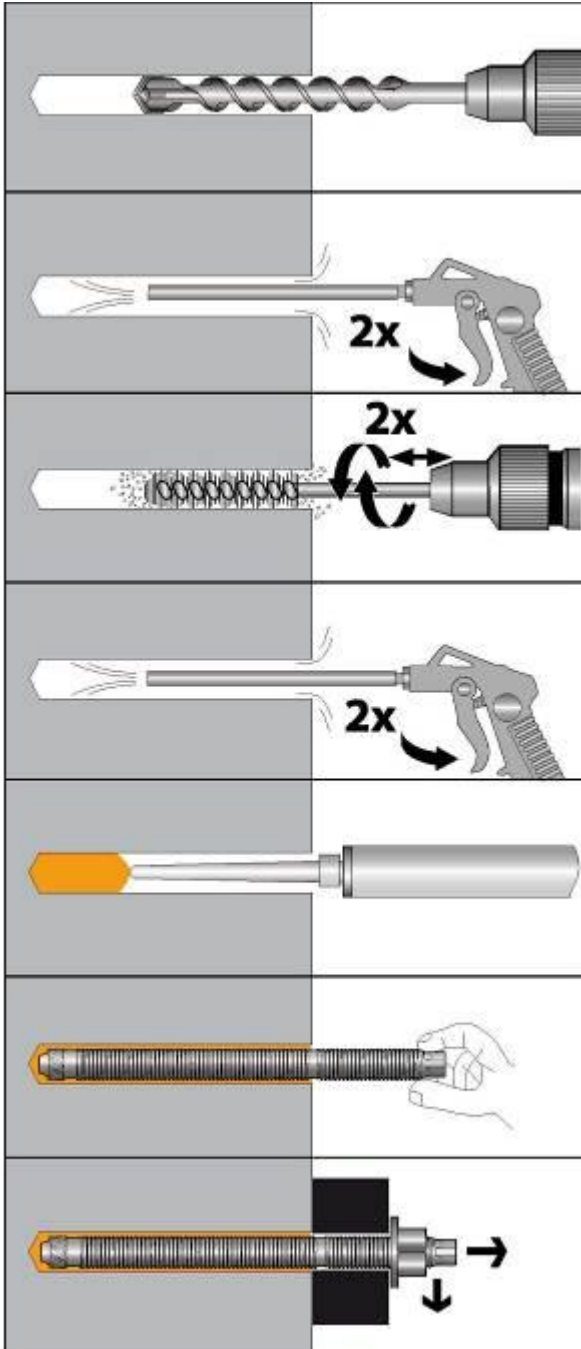

Drill hole of diameter (d_0) and depth (h_0) with a hammer drill set in rotation-hammer mode using an appropriately carbide drill bit.

Using compress air cleaning (mini 6 bars), use the appropriate extension and air nozzle, starting from the bottom of the hole blow out at least 2 times and until no dust is evacuated.

Using the relevant SPIT brush and extension fitted on a drilling machine (dimensions of the brush see table 8 & 9), starting from the top of the hole in rotation, move downward to the bottom of the hole then move upward to the top of the hole. Repeat this operation.

Using compress air cleaning (mini 6 bars), use the appropriate extension and air nozzle, starting from the bottom of the hole blow out at least 2 times and until no dust is evacuated.

Screw the mixing nozzle onto the cartridge and dispense the first part to waste until an even colour is achieved for each new cartridge or mixing nozzle. Use tube extensions for holes deeper than 250 mm. Starting from the bottom of the hole fill uniformly. In order to avoid air pocket, withdraw slowly the mixing nozzle while injecting the resin. Fill the hole until 1/2 full.

Insert the rod or rebar, slowly and with a slight twisting motion in respect of the gel time indicated in table 4. Remove excess resin from around the mouth of the hole before it sets. Control the embedment depth

Do not disturb anchor between specified cure time (acc. to table 4)

Attach the fixture and tight the nut at the specified torque

SPIT MULTI-MAX

Installation instruction

Annex B3

Table C1: Characteristic values of resistance to tension loads.
Design method TR 029

SPIT MULTI-MAX with threaded rod			M8	M10	M12	M16	M20	M24
Steel failure								
Characteristic resistance property class 5.8	$N_{Rk,S}$	[kN]	18,3	29,0	42,2	78,5	122,5	176,5
Characteristic resistance property class 6.8	$N_{Rk,S}$	[kN]	22,0	34,8	50,6	94,2	147,0	211,8
Characteristic resistance property class 8.8	$N_{Rk,S}$	[kN]	29,3	46,4	67,4	125,6	196,0	282,4
Characteristic resistance property class 10.9	$N_{Rk,S}$	[kN]	36,6	58,0	84,3	157,0	245,0	353,0
Stainless Steel Failure								
Characteristic resistance property class A4-70	$N_{Rk,S}$	[kN]	25,6	40,6	59,0	109,9	171,5	247,1
Characteristic resistance property class HCR	$N_{Rk,S}$	[kN]	23,8	37,7	54,8	102,1	159,3	229,5
Partial safety factor property class 5.8, 6.8 et 8.8 property class 10.9 property class A4-70 property class HCR	γ_{Ms}^1	[-]	1,50 1,40 1,87 2,60					
Combined Pull-out and Concrete cone failure								
Diameter of threaded rod	d	[mm]	8	10	12	16	20	24
Characteristic bond resistance in non-cracked concrete C20/25								
Temperature range I ²⁾ : -40°C / 40°C	$\tau_{Rk,ucr}$	[N/mm ²]	9,0	9,0	8,5	8,0	8,0	7,5
Increasing factor for τ_{Rkp} in non-cracked concrete	ψ_c	C30/37	1,04					
		C40/50	1,07					
		C50/60	1,09					
Splitting failure								
Edge distance $c_{cr,sp}$ [mm] for	$h / h_{ef} \geq 2,0$	$1,0 h_{ef}$						
	$2,0 > h / h_{ef} > 1,3$	$4,6 h_{ef} - 1,8 h$						
	$h / h_{ef} \leq 1,3$	$2,26 h_{ef}$						
Spacing	$s_{cr,sp}$	[mm]	$2 \times c_{cr,sp}$					
Partial safety installation	$\gamma_2 = \gamma_{Inst}$	[-]	Nettoyage standard	1,0	1,2		-	-
			Nettoyage Premium	1,0	1,2			

¹⁾ In absence of other national regulations

²⁾ Maximum short and long term temperatures;

Table C2: Displacements under tension loads

Concrete C20/25 to C50/60			M8	M10	M12	M14	M16	M30
Displacement	δ_{No}	[mm/(N/mm ²)]	0,038	0,025	0,018	0,011	0,007	0,005
	δ_{Nc}	[mm/(N/mm ²)]	0,256	0,169	0,121	0,071	0,047	0,034

SPIT MULTI-MAX

Annex C1

Design according to TR029
Characteristic values of resistance to tension loads - Displacements

Table C3: Characteristic values of resistance to shear loads.
Design method TR 029

SPIT MULTI-MAX with threaded road			M8	M10	M12	M16	M20	M24
Steel failure without lever arm								
Characteristic resistance property class 5.8	$V_{Rk,s}$	[kN]	9,2	14,5	21,1	39,3	61,3	88,3
Characteristic resistance property class 6.8	$V_{Rk,s}$	[kN]	11,0	17,4	25,3	47,1	73,5	105,9
Characteristic resistance property class 8.8	$V_{Rk,s}$	[kN]	14,6	23,2	33,7	62,8	98,0	141,2
Partial safety factor	$\gamma_{Ms}^{1)}$	[-]	1,25					
Characteristic resistance property class 10.9	$V_{Rk,s}$	[kN]	18,3	29,0	42,2	78,5	122,5	176,5
Partial safety factor	$\gamma_{Ms}^{1)}$	[-]	1,50					
Characteristic resistance property class A4-70	$V_{Rk,s}$	[kN]	12,8	20,3	29,5	55,0	85,8	123,6
Partial safety factor	$\gamma_{Ms}^{1)}$	[-]	1,56					
Characteristic resistance property class HCR	$V_{Rk,s}$	[kN]	11,9	18,9	27,4	51,0	79,6	114,7
Partial safety factor	$\gamma_{Ms}^{1)}$	[-]	2,17					
Rupture de l'acier avec bras de levier								
Characteristic resistance property class 5.8	$M_{Rk,s}^0$	[N.m]	18,7	37,4	65,5	166,5	324,5	561,3
Characteristic resistance property class 6.8	$M_{Rk,s}^0$	[N.m]	22,5	44,9	78,6	199,8	389,4	673,5
Characteristic resistance property class 8.8	$M_{Rk,s}^0$	[N.m]	30,0	59,8	104,8	266,4	519,3	898,0
Partial safety factor	$\gamma_{Ms}^{1)}$	[-]	1,25					
Characteristic resistance property class 10.9	$M_{Rk,s}^0$	[N.m]	37,5	74,8	131,0	333,0	649,1	1122,6
Partial safety factor	$\gamma_{Ms}^{1)}$	[-]	1,50					
Characteristic resistance property class A4-70	$M_{Rk,s}^0$	[N.m]	26,2	52,3	91,7	233,1	454,4	785,8
Partial safety factor	$\gamma_{Ms}^{1)}$	[-]	1,56					
Characteristic resistance property class HCR	$M_{Rk,s}^0$	[N.m]	24,4	48,6	85,2	216,4	421,9	729,7
Partial safety factor	$\gamma_{Ms}^{1)}$	[-]	2,17					
Rupture du béton par effet de levier								
Factor in equation (5.7) of TR 029, Section 5.2.3.3	k	[-]	2,0					
Partial safety factor	$\gamma_2 = \gamma_{Inst}$	[-]	1,0					
Concrete edge failure								
Concrete edge failure see chapter 5.2.3.4 of Technical Report TR 029								

¹⁾ In absence of other national regulations

Table C4: Displacements under shear loads

Concrete C20/25 to C50/60			M8	M10	M12	M14	M16	M30
Displacement	δ_{N0}	[mm/(N/mm ²)]	0,11	0,10	0,09	0,08	0,06	0,04
	δ_{Nc}	[mm/(N/mm ²)]	0,17	0,15	0,14	0,12	0,09	0,06

SPIT MULTI-MAX

Annex C2

Design according to TR029

Characteristic values of resistance to shear loads - Displacements

Table C5: Characteristic values of resistance to tension loads.
Design acc. CEN/TS 1992-4-5

SPIT MULTI-MAX with threaded rod			M8	M10	M12	M16	M20	M24
Steel failure								
Characteristic resistance property class 5.8	$N_{Rk,S}$	[kN]	18,3	29,0	42,2	78,5	122,5	176,5
Characteristic resistance property class 6.8	$N_{Rk,S}$	[kN]	22,0	34,8	50,6	94,2	147,0	211,8
Characteristic resistance property class 8.8	$N_{Rk,S}$	[kN]	29,3	46,4	67,4	125,6	196,0	282,4
Characteristic resistance property class 10.9	$N_{Rk,S}$	[kN]	36,6	58,0	84,3	157,0	245,0	353,0
Stainless Steel Failure								
Characteristic resistance property class A4-70	$N_{Rk,S}$	[kN]	25,6	40,6	59,0	109,9	171,5	247,1
Characteristic resistance property class HCR	$N_{Rk,S}$	[kN]	23,8	37,7	54,8	102,1	159,3	229,5
Partial safety factor property class 5.8, 6.8 et 8.8 property class 10.9 property class A4-70 property class HCR	γ_{Ms}^1	[-]	1,50 1,40 1,87 2,60					
Combined Pull-out and Concrete cone failure								
Diameter of threaded rod	d	[mm]	8	10	12	16	20	24
Characteristic bond resistance in non-cracked concrete C20/25								
Temperature range I ²⁾ : -40°C / 40°C	$\tau_{Rk,ucr}$	[N/mm ²]	9,0	9,0	8,5	8,0	8,0	7,5
Increasing factor for τ_{Rkp} in non-cracked concrete	ψ_c	C30/37	1,04					
		C40/50	1,07					
		C50/60	1,09					
Factor acc. CEN/TS 1992-4-5, § 6.2.2.3	k_{ucr}	[-]	10,1					
Edge distance	$c_{cr,N}$	[-]	1,5 h_{ef}					
Spacing	$s_{cr,N}$	[-]	3 h_{ef}					
Rupture par fendage								
Edge distance $c_{cr,sp}$ [mm] for	$h / h_{ef} \geq 2,0$	1,0 h_{ef}						
	$2,0 > h / h_{ef} > 1,3$	4,6 h_{ef} - 1,8 h						
	$h / h_{ef} \leq 1,3$	2,26 h_{ef}						
Spacing	$s_{cr,sp}$	[mm]	2 x $c_{cr,sp}$					
Partial safety installation	$\gamma_2 = \gamma_{Inst}$	[-]	Nettoyage standard	1,0	1,2		-	-
			Nettoyage Premium	1,0	1,2			

¹⁾ In absence of other national regulations

/ ²⁾ Maximum short and long term temperatures;

SPIT MULTI-MAX

Annex C3

Design CEN/TS 1992-4-5:
Characteristic values of resistance to tension loads

Table C6: Characteristic values of resistance to shear loads.
Design acc. CEN/TS 1992-4-5

SPIT MULTI-MAX with threaded road			M8	M10	M12	M16	M20	M24
Steel failure without lever arm								
Characteristic resistance property class 5.8	$V_{Rk,s}$	[kN]	9,2	14,5	21,1	39,3	61,3	88,3
Characteristic resistance property class 6.8	$V_{Rk,s}$	[kN]	11,0	17,4	25,3	47,1	73,5	105,9
Characteristic resistance property class 8.8	$V_{Rk,s}$	[kN]	14,6	23,2	33,7	62,8	98,0	141,2
Partial safety factor	$\gamma_{Ms}^{1)}$	[-]	1,25					
Characteristic resistance property class 10.9	$V_{Rk,s}$	[kN]	18,3	29,0	42,2	78,5	122,5	176,5
Partial safety factor	$\gamma_{Ms}^{1)}$	[-]	1,50					
Characteristic resistance property class A4-70	$V_{Rk,s}$	[kN]	12,8	20,3	29,5	55,0	85,8	123,6
Partial safety factor	$\gamma_{Ms}^{1)}$	[-]	1,56					
Characteristic resistance property class HCR	$V_{Rk,s}$	[kN]	11,9	18,9	27,4	51,0	79,6	114,7
Partial safety factor	$\gamma_{Ms}^{1)}$	[-]	2,17					
Ductility factor acc. CEN/TS 1992-4-5, § 6.3.2.1	k_2	[-]	0,8					
Rupture de l'acier avec bras de levier								
Characteristic resistance property class 5.8	$M^0_{Rk,s}$	[N.m]	18,7	37,4	65,5	166,5	324,5	561,3
Characteristic resistance property class 6.8	$M^0_{Rk,s}$	[N.m]	22,5	44,9	78,6	199,8	389,4	673,5
Characteristic resistance property class 8.8	$M^0_{Rk,s}$	[N.m]	30,0	59,8	104,8	266,4	519,3	898,0
Partial safety factor	$\gamma_{Ms}^{1)}$	[-]	1,25					
Characteristic resistance property class 10.9	$M^0_{Rk,s}$	[N.m]	37,5	74,8	131,0	333,0	649,1	1122,6
Partial safety factor	$\gamma_{Ms}^{1)}$	[-]	1,50					
Characteristic resistance property class A4-70	$M^0_{Rk,s}$	[N.m]	26,2	52,3	91,7	233,1	454,4	785,8
Partial safety factor	$\gamma_{Ms}^{1)}$	[-]	1,56					
Characteristic resistance property class HCR	$M^0_{Rk,s}$	[N.m]	24,4	48,6	85,2	216,4	421,9	729,7
Partial safety factor	$\gamma_{Ms}^{1)}$	[-]	2,17					
Concrete pryout failure								
Factor in equation (27) of CEN/TS 1992-4-5, § 6.3.3	k_3	[-]	2,0					
Partial safety factor	$\gamma_2 = \gamma_{Inst}$	[-]	1,0					
Concrete edge failure								
Concrete edge failure, see CEN/TS 1992-4-5, § 6.3.4								

¹⁾ In absence of other national regulations

SPIT MULTI-MAX

Annex C4

Design **CEN/TS 1992-4-5**:
Characteristic values of resistance to shear loads